

MULTITEL EC 20 ALU/AF – MERCEDES 308 C.D.I.

Ente	Rev.	Descrizione	Data	Dis.	Contr.	Ap.AQ
MRK	0	EMISSIONE	28-11-00	W.B.		

D30514

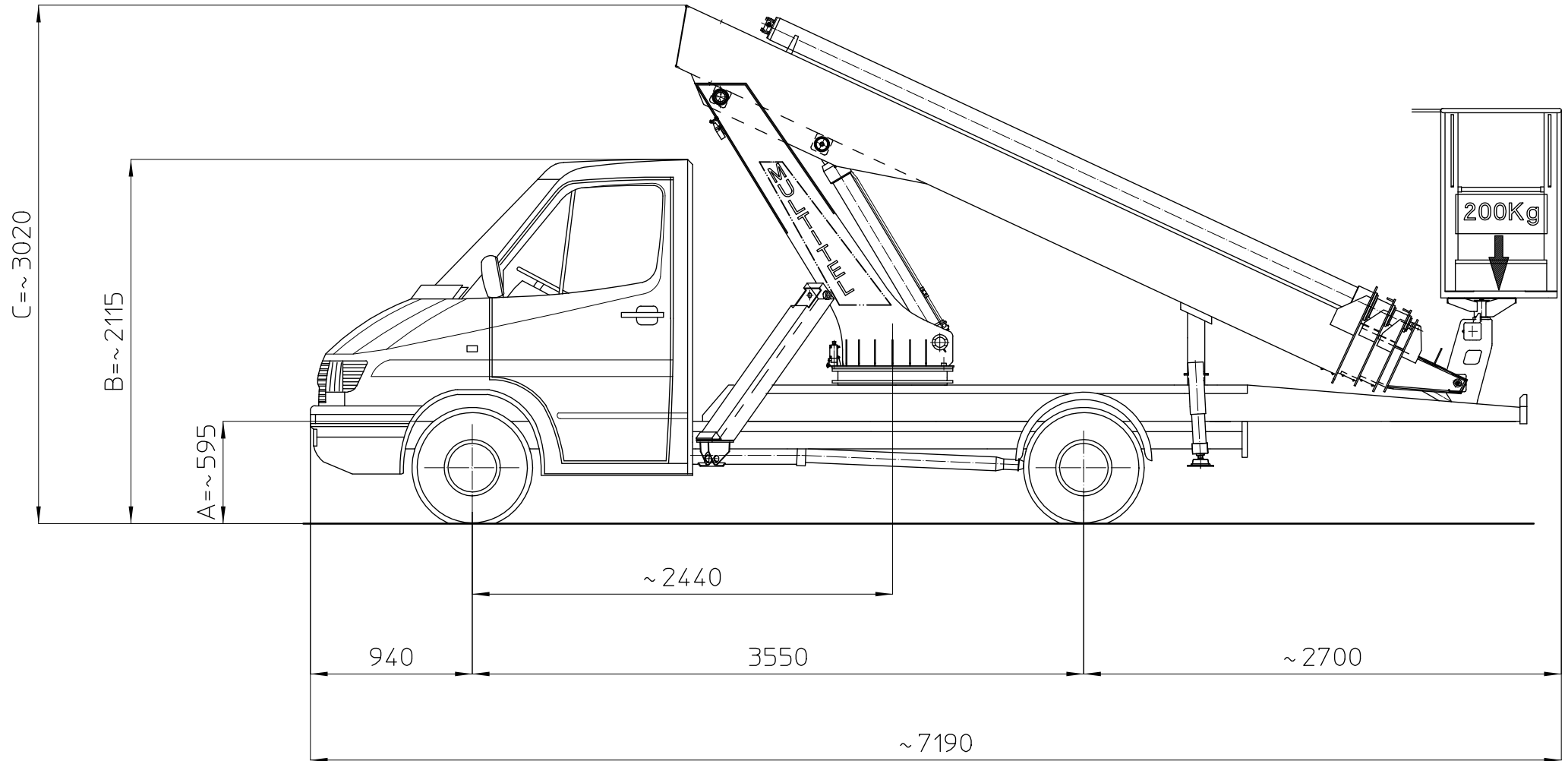

Le quote A-B sono relative alle dimensioni dell'autocarro, quindi devono essere verificate sullo stesso.
La quota C (altezza totale) e' subordinata alle quote A-B.

Les cotes A-B sont relatives aux dimensions du porteur, donc elles doivent être vérifiées sur le porteur même.
La cote C (hauteur totale) est subordonnée aux cotes A-B.

The dimensions A-B are related to the truck sizes, therefore they must be verified.
The dimension C (total height) is subject to A-B.

Die Abmessungen A-B betreffen die Fahrzeugmasse, daher sollen sie geprüft werden.
Die Abmessung C (Gesamthöhe) hängt von A-B Abmessungen ab.

MULTITEL Ec 20 ALU/AF

DIS. D21925

Ente	Rev.	Descrizione	Data	Dis.	Contr.	Ap.AQ
MRK	0	EMISSIONE	04-10-95	Rinaudo		

200Kg	80Kg
-------	------

SBRACCIO DI LAVORO	7.5 m	9.4 m	±5%
WORKING OUTREACH	7.5 m	9.4 m	±5%
DEPORT DE TRAVAIL	7.5 m	9.4 m	±5%
SEITLICHE REICHWEITE	7.5 m	9.4 m	±5%

